

SensoWash®

Mounting instructions

Wall-mounted WC

Instrucciones de montaje

Inodoro suspendido

Notice de montage

Cuvette suspendue

254459 .. 92

256359 .. 92

253359 .. 92

222659 .. 92

252959 .. 92

254259 .. 92

253759 .. 92

255059 .. 92

256159 .. 92

252559 .. 92

251159 .. 92





Important information



Electrical/water Installation

4

Información importante

Instalación eléctrica/instalación de agua

6

Remarques importantes

Installation électrique/installation hydraulique

8

en
es
fr



Installation, Montaje, Montage

10



Important information

Mounting instructions information

These mounting instructions come as part of the Duravit shower toilet and should be read carefully prior to installation.

Explanation of the key words and symbols

! DANGER High risk, lethal hazards, severe injuries

NOTE To avoid property damage



Link to the **Electrical Installation** section



Link to the **mounting instructions** in this section



Link to the **Water Installation** section



Link to other **instructions**



Inspection (e.g. for scratches)



Inspection to collect water



Do not kink hose

> Action required

Target readership and qualifications

The shower toilet and associated water connection should only be installed by qualified plumbers. The electrical installation should only be carried out by qualified electricians.

NOTE

Local installation regulations, country-specific standards and the low voltage directives must be observed at all times.

NOTE

Do NOT install the shower toilet in rooms where there is a danger of frost. The room temperature must not be less than 39 °F

Safety instructions

! DANGER Risk of fatal electric shock.

- > Do NOT remove individual shower toilet components.
- > If the supply cord on this unit is damaged, it must be replaced by the manufacturer, the service agent or similarly qualified persons in order to avoid a hazard.

Mounting instructions

Please read pre-installation information sheets prior to the installation. These are available to download on the Internet at www.duravit.com.

The shower toilet seat installation is described in separate instructions.

An installation video of the complete shower toilet is available at pro.duravit.com/mounting.



Simply use this QR code

4 Measuring clearance y

7 Install the sound insulation set

- > If the sound insulation set is included with the delivery, take z into account in the clearance between the wall and bolt:
Clearance = $z+y+1''$.
- > Screw the bolt onto the hanger bolt until you achieve the calculated clearance to the wall.
- > Install the sound insulation set.

21 Attaching the ceramics to the wall

- > Position the ceramics on the wall. Ensure that the hose is not kinked or trapped.



Electrical installation



Water installation



Power supply	6..... .. 1	100 – 120 V 50/60 Hz
Max. rated power		1.65 kW
Circuit breaker		$I_N = 16$ A
RCCB		$I_N = 30$ mA
Protection type		IP X4
Protection class		1

Cold water	1/2"
Water pressure	10 – 109 psi (0.07 – 0.75 MPa)
Water hardness	max. 2.4 mmol/l

NOTE

- > Install a water softener with water hardness ≥ 2.4 mmol/l ($\geq 14^\circ$ dH and/or 24° fH).

Position of electrical / water connection

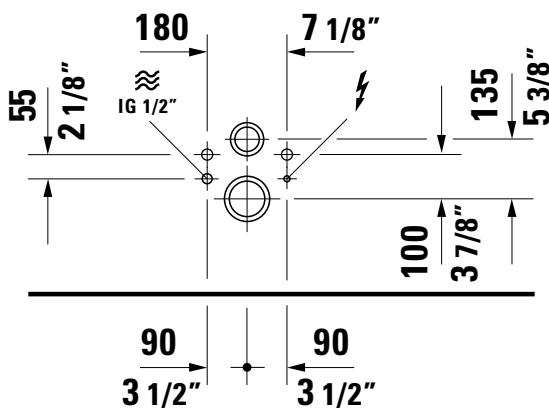

Pre-Installation

DANGER

Risk of fatal electric shock

- > Disconnect electrical components from the power supply before the installation.
- > Check that all components are de-energised.
- > Prevent the power supply from being switched on accidentally.
- > Lay a permanent power supply line:
 - Please observe the position of the electrical connection
 - Leave at least 31 1/2" of feed cable exposed
- > Install circuit breaker
 - Connect a separate upstream circuit breaker
 - Connect an upstream residual current device (RCD) separating all poles
- > Appliances have to be correctly earthed.

24 Connecting the cable

- > Please observe the L, N and PE conductors.

26 Installing junction box

- > Fix the junction box in the Wall-mounted WC in the designated place.

Pre-Installation

- > Install the water connection and water outlet in the specified areas.

DANGER

Health risk and potential product damage.

- > Supply the shower toilet with cold drinking water from the main water system.
- > Do not connect any waste water, grey water, industrial water, sea water or other untreated or semi-treated water.

11 Connecting the water

NOTE

Avoiding any malfunctions.

- > Only use the water supply hoses provided.



Información importante

Acerca de las instrucciones de montaje

Estas instrucciones de montaje acompañan al WC con ducha Duravit y es necesario leerlas cuidadosamente antes del montaje.

Explicación de las indicaciones y símbolos de advertencia



PELIGRO

en caso de riesgo elevado, peligros mortales, lesiones graves

ADVERTENCIA

Para evitar daños materiales



Indica el capítulo **Instalación eléctrica**



Se refiere a una **Indicación de montaje** en este capítulo



Indica el capítulo **Instalación de agua**



Referencia a otras **instrucciones**



Fíjese que no haya, por ejemplo, rasguños



Es imperativo recoger el agua



No doble el tubo flexible

> Se requiere una acción

Instaladores y cualificación

El asiento con lavado y la instalación correspondiente de agua solo pueden ser montados por instaladores de sanitarios con la formación adecuada. La instalación eléctrica solo podrá ser realizada por electricistas autorizados.

ADVERTENCIA

Deberán cumplirse sin restricciones las instrucciones de instalación de las empresas de suministro locales, las normas específicas de cada país y las directivas de baja tensión.

ADVERTENCIA

NO monte el WC con ducha en espacios con riesgo de que se produzcan heladas. La temperatura ambiente no deberá ser inferior a los 39 °F.

Advertencias de seguridad



PELIGRO

Peligro de muerte por descarga eléctrica.

- > NO desmontar los diferentes componentes del WC con ducha.
- > Si se ha dañado el cable de conexión eléctrico de este aparato, este tendrá que ser cambiado por el fabricante o el servicio de asistencia técnica del mismo o por una persona cualificada similar, para evitar cualquier peligro.

Indicaciones de montaje

Antes de llevar a cabo el montaje, hay que tener en cuenta las fichas de preinstalación. Pueden descargarse en www.duravit.com.

El montaje del accesorio para el WC con ducha se describe en otras instrucciones.

Puede encontrar un vídeo de instalación de todo el WC con ducha en pro.duravit.com/mounting.



Use simplemente para ello este código QR.

4 Medir la distancia y

7 Montar el juego de aislamiento acústico

- > Si el juego de aislamiento acústico se incluye en el volumen de suministro, hay que considerar z en la distancia entre la pared y los pernos: $\text{distancia} = z + y + 1''$.
- > Girar los pernos en el tornillo de rosca combinada hasta que se alcance la distancia calculada con la pared.
- > Montar el juego de aislamiento acústico.

21 Empujar la cerámica en la pared

- > Colocar la cerámica en la pared. Hay que prestar atención a que el tubo flexible no se doble o se pille.



Instalación eléctrica



Instalación del agua



Alimentación eléctrica	6..... .. 1	100 – 120 V 50/60 Hz
Máx. potencia nominal		1,65 kW
Dispositivo de seguridad	$I_N = 16$ A	
RCD	$I_N = 30$ mA	
Tipo de protección		IP X4
Clase de protección		1

Agua fría	1/2"
Presión de agua	10 – 109 psi (0.07 – 0.75 MPa)
Dureza del agua	máx. 2,4 mmol/l

ADVERTENCIA

- > Si la dureza del agua es $\geq 2,4$ mmol/l ($\geq 14^\circ$ dH o 24° fH) hay que instalar un ablandador de agua.

Posición de la conexión eléctrica / toma de agua

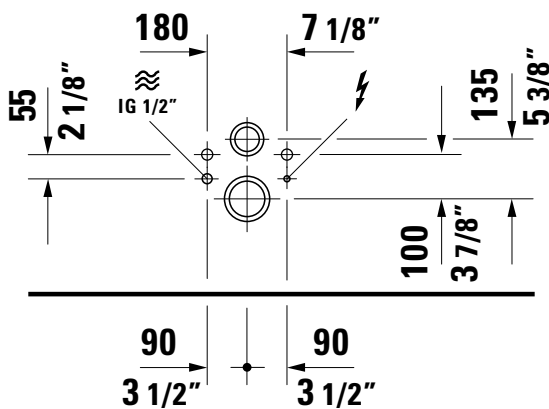

Preinstalación



PELIGRO

Peligro de muerte por descarga eléctrica

- > Antes de iniciar la instalación se deben desconectar los componentes eléctricos de la red eléctrica.
- > Comprobar que todos los componentes estén sin tensión.
- > Asegurarse que no se pueda conectar accidentalmente el suministro de corriente.
- > Colocar el tubo de admisión permanente de la alimentación de corriente:
 - Observar la posición de la conexión eléctrica
 - Hacer que la línea eléctrica sobresalga 31 1/2" como mín.
- > Instalar el dispositivo de seguridad.
 - Intercalar el dispositivo de seguridad separado
 - Intercalar el dispositivo de protección de corriente de falla que desconecta todos los polos (RCD)
- > Poner a tierra el aparato de forma correcta.

24 Conectar el cable

- > Observar los conductores L, N, PE

26 Montar la caja de conexión

- > Fijar la caja de conexión del inodoro suspendido en el lugar previsto.

Preinstalación

- > Instalar la toma de agua y la salida de agua en las áreas indicadas.



PELIGRO

Riesgo para la salud y posibles daños materiales.

- > El asiento de lavado recibe agua potable (PWC) de la tubería principal de agua.
- > No conectar aguas residuales, aguas grises, aguas industriales, agua salada o aguas de otro tipo, ni tampoco agua que no se haya tratado o que se haya tratado parcialmente.

11 Conectar el agua

ADVERTENCIA

Para evitar fallos de funcionamiento.

- > Usar solo los tubos flexibles de agua suministrados.



Remarques importantes

Concernant la notice de montage

Cette notice de montage fait partie de l'abattant douche Duravit et doit être lue attentivement avant le montage.

Explication des avertissements et symboles

! DANGER Risque élevé : danger de mort, blessures graves

INFO UTILE Pour éviter les dégâts matériels



Référence au chapitre **Installation électrique**



Voir la **Consigne de montage** dans ce chapitre



Référence au chapitre **Installation hydraulique**



Voir une autre **notice**



Invitation à vérifier (p. ex. les rayures)



Invitation à recueillir de l'eau



Ne pas couder le flexible

> Intervention nécessaire

Groupe cible et qualification

L'abattant douche et le raccord d'eau correspondant doivent exclusivement être montés par des installateurs sanitaires dûment formés. L'installation électrique doit impérativement être réalisée par des électriciens qualifiés.

INFO UTILE

Les prescriptions d'installation des sociétés de distribution locales, les normes nationales et les directives basse tension doivent être respectées sans réserve.

INFO UTILE

Ne PAS monter l'abattant douche dans des locaux exposés au gel. La température ambiante ne doit pas être inférieure à 39 °F.

Consignes de sécurité

! DANGER **Danger de mort par électrocution.**

- > NE PAS démonter les différents composants de l'abattant douche.
- > Si le câble d'alimentation de cet appareil est endommagé, il doit être remplacé par le fabricant ou son service après-vente ou par une personne avec un niveau de compétence équivalent afin d'éviter tout danger.

Consignes de montage

Avant le montage, lire les notices techniques de préinstallation. Celles-ci peuvent être téléchargées sur Internet via le site www.duravit.com.

Le montage de la réhausse de l'abattant WC douche est décrit dans une notice séparée.

Une vidéo d'installation de l'abattant douche complet est disponible sur pro.duravit.com/mounting.



Utilisez pour cela simplement ce code QR

4 Mesurer le dégagement

7 Monter le kit de protection acoustique

- > Si le kit de protection acoustique est fourni, ajouter z au calcul du dégagement entre le mur et la cheville :
dégagement = z+y+1".
- > Tourner la cheville sur la vis à double filetage jusqu'à ce que le dégagement par rapport au mur défini soit atteint.
- > Monter le kit de protection acoustique.

21 Positionnement de la céramique au mur

- > Positionner la céramique sur le mur. Veiller ce faisant à ce que le flexible ne soit pas coudé ou coincé.



Installation électrique



Installation hydraulique



Alimentation électrique	6..... .. 1	100 – 120 V 50/60 Hz
Puissance nominale max.		1,65 kW
Fusible		$I_N = 16$ A
RCD		$I_N = 30$ mA
Indice de protection		IP X4
Classe de protection		1

Eau froide	1/2"
Pression de l'eau	10 – 109 psi (0.07 – 0.75 MPa)
Dureté de l'eau	2,4 mmol/l max.

INFO UTILE

- > En cas de dureté de l'eau $\geq 2,4$ mmol/l ($\geq 14^\circ$ dH resp. 24° fH), installer un adoucisseur d'eau.

Position du raccord électrique / raccord d'eau

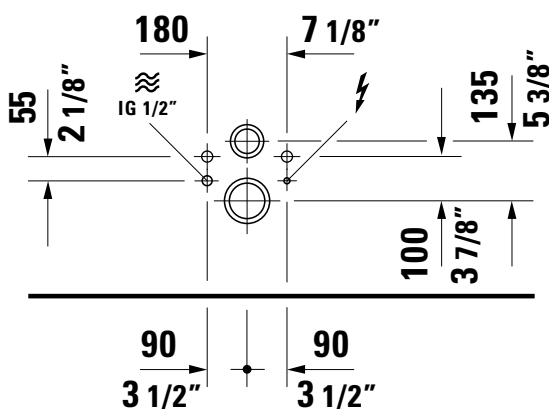

Pré-installation

DANGER

Danger de mort par électrocution

- > Avant l'installation, débrancher les composants électriques du réseau électrique.
- > Vérifier si tous les composants sont hors tension.
- > Empêcher la remise en marche de l'alimentation électrique.
- > Poser la conduite de raccordement électrique permanente :
 - Tenir compte de la position du raccord électrique
 - Faire dépasser la ligne d'arrivée sur au moins $31 \frac{1}{2}$ "
- > Installer un disjoncteur.
 - connecter le fusible séparé en amont
 - connecter le dispositif de protection contre les courants de fuite à coupure sur tous les pôles
- > Mettre l'appareil correctement à la terre.

24 Brancher la conduite

- > Tenir compte des conducteurs L, N, PE.

26 Anschlussdose montieren

- > Fixer la prise de raccordement sur l'emplacement prévu de la cuvette suspendue.

Pré-installation

- > Installer le raccordement d'eau et l'évacuation d'eau dans des zones indiquées.

DANGER

Risque pour la santé et endommagement possible du produit.

- > Alimenter l'abattant douche avec de l'eau potable provenant de la conduite d'eau principale.
- > Ne pas raccorder aux eaux usées, à l'eau grise, l'eau sanitaire, l'eau de mer ou l'eau non ou faiblement traitée.

11 Raccorder l'eau

INFO UTILE

Eviter tout dysfonctionnement.

- > Utiliser uniquement les flexibles d'alimentation en eau fournis.

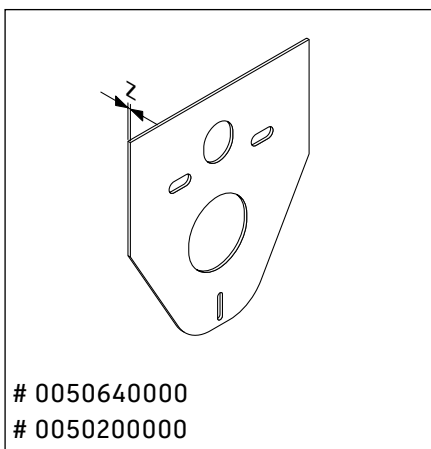
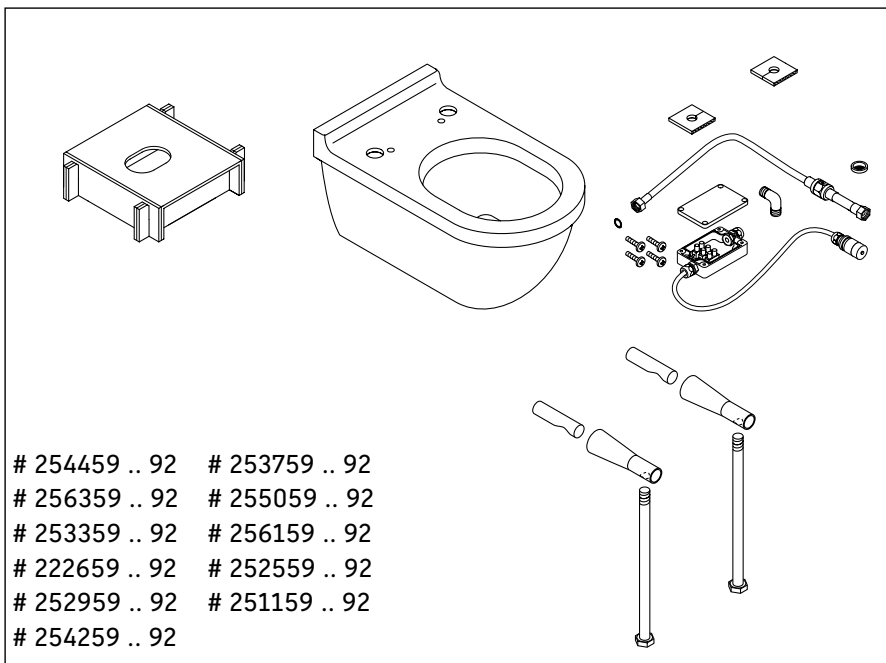

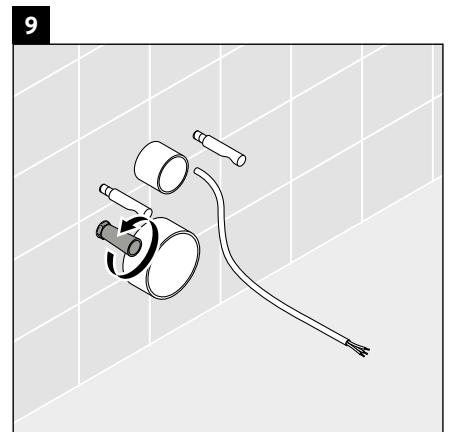
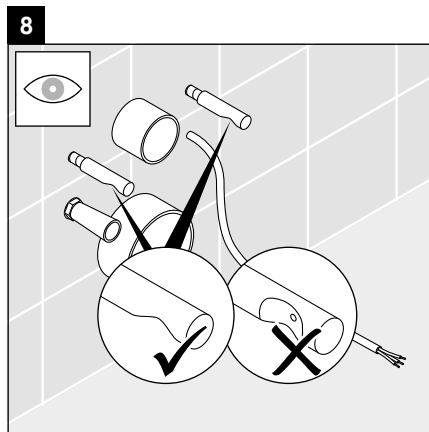
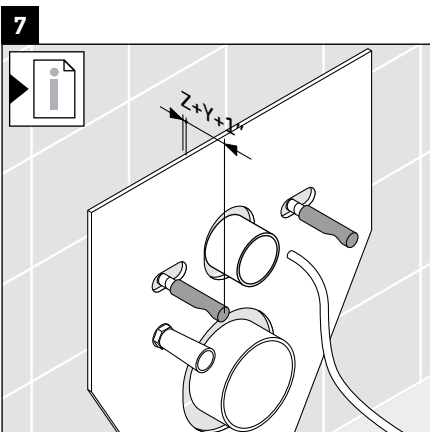
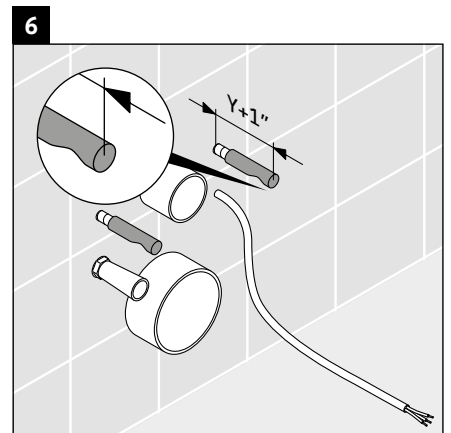
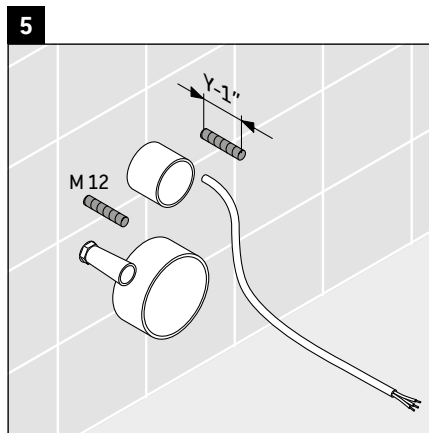
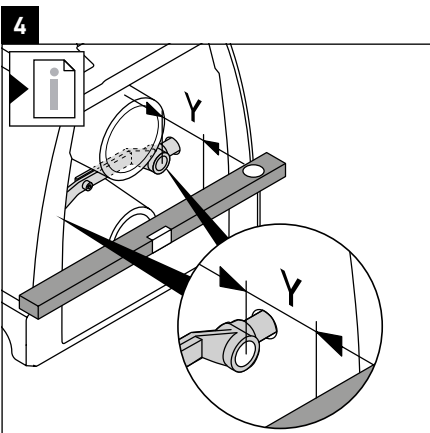
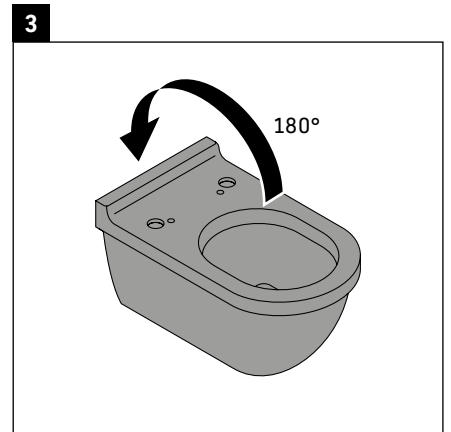
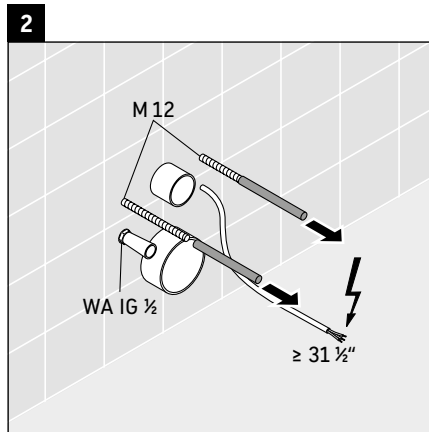
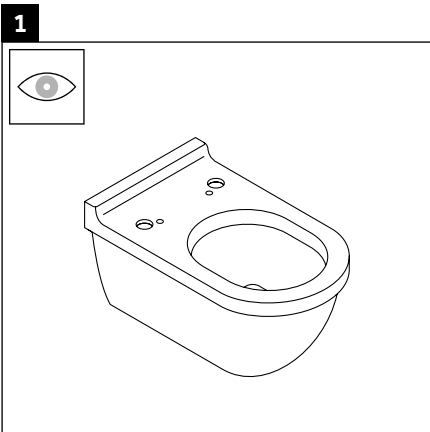

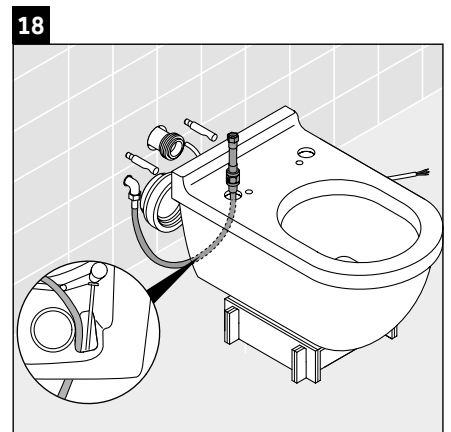
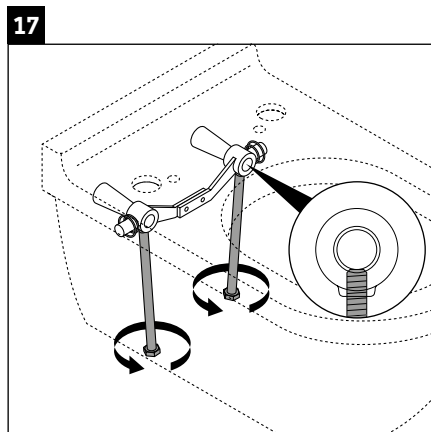
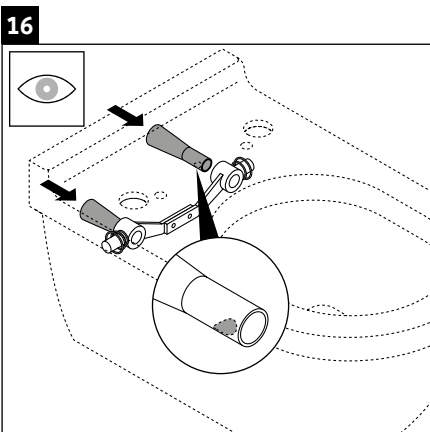
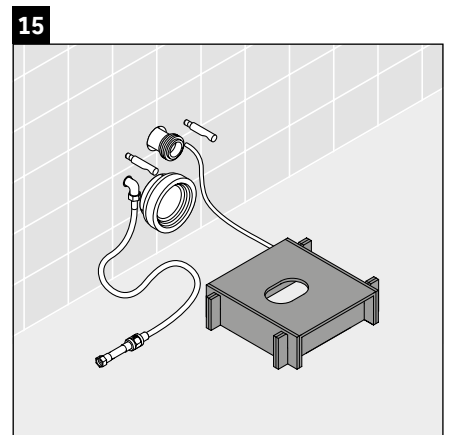
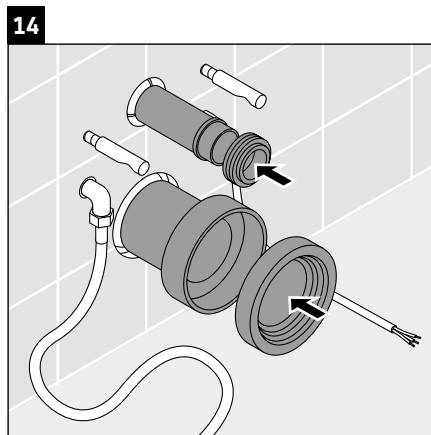
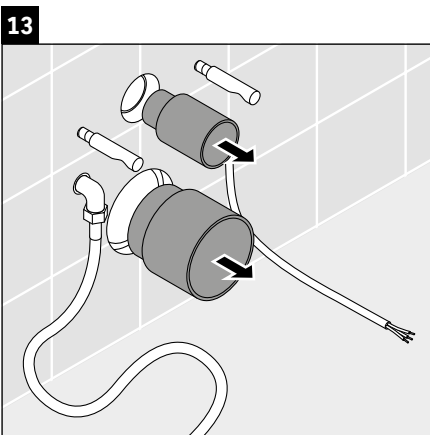
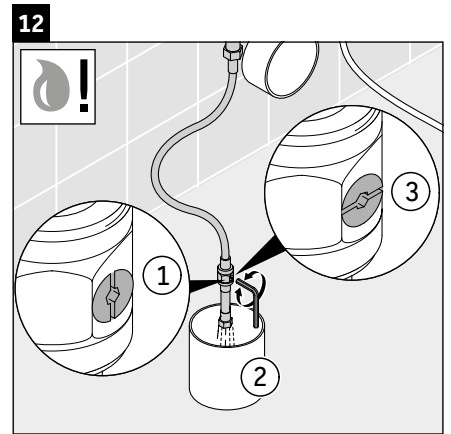
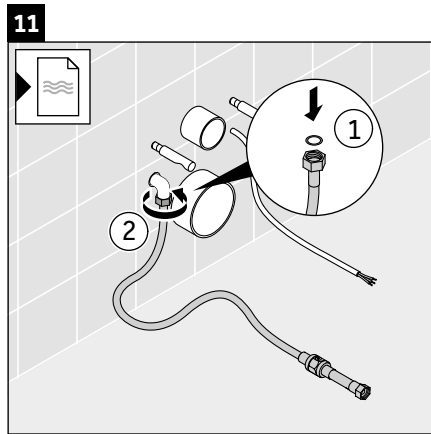
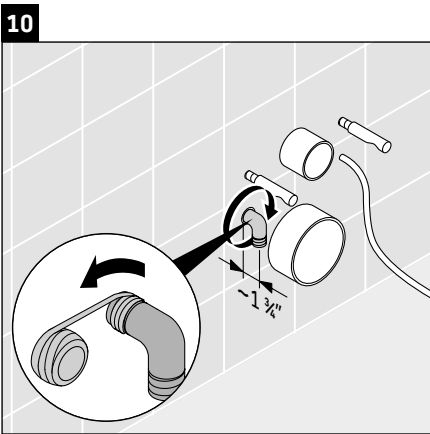

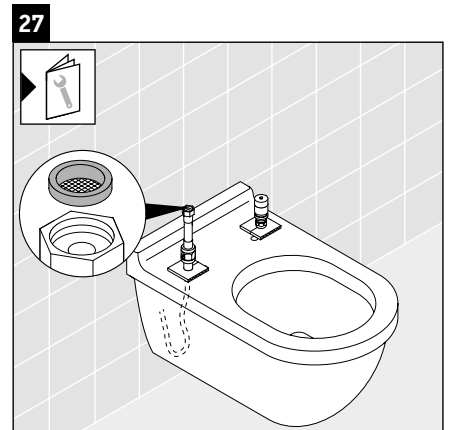
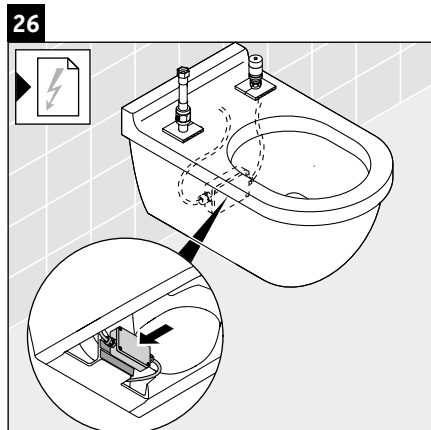
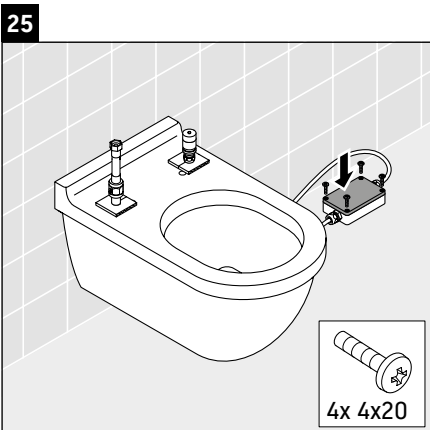
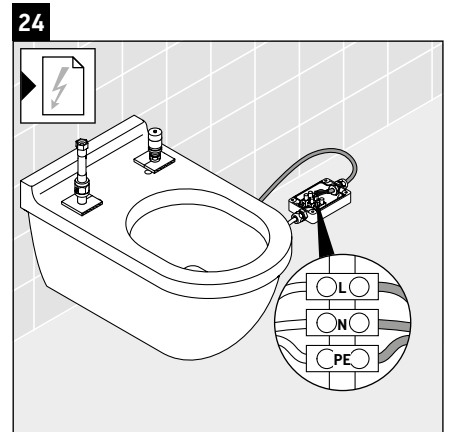
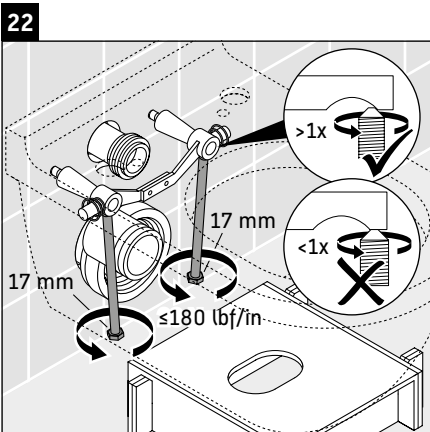
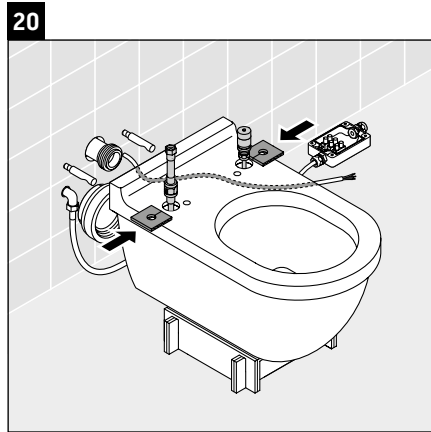
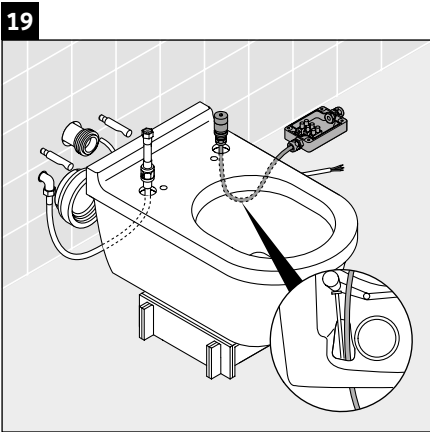

DURAVIT AG
P.O. Box 240
Werderstr. 36
78132 Hornberg
Germany
Phone +49 78 33 70 0
Fax +49 78 33 70 289
info@duravit.com
www.duravit.com

